

INSTALLATION AND OPERATING INSTRUCTIONS

R-3W-SR **SOLID RED** Voltage Indicator

R-3W-SR Voltage Indicators are used to visually notify the presence of both AC & DC voltages (stored energy). This product is intended to be used on Three Phase, 4-wire AC applications. It can also be used in Single Phase, 3-wire AC applications.

Non-Hazardous Locations

Indoor	Indoor / Outdoor	Ingress Protection
UL Type 12, 13	UL Type 4, 4X	IP 67

Approvals

UL 508	CSA C22.2 No. 14-13	UL61010-1 3 rd Ed.
CAT III 1000V	CAT IV 600V	CE
CSA C22.2 No. 61010-1-12 3 rd Edition		IEC 61010-1-030 1 st Ed.

For technical questions, contact: Grace Technologies, Inc./ 1515 E Kimberly Road,
Davenport, IA 52807 / 800.280.9517 563.386.9639 (Fax)





www.pesd.com



Approvals:

UL LISTED file No. 256847
 Per UL 508 CAN/CSA-C22.2 No. 14-13
 CAT FILE No. E311256
 Per UL61010-1, 3rd Edition
 CAN/CSA-C22.2 No. 61010-1-12 3rd Ed.
 IEC 61010-1-030 1st Ed.

CAT III 1000V 
 CAT IV 600V 
 DC or AC-rms to Ground
 (Peak Impulse Transient 8000V
 20 repetitions, 2 ohm source)

 UL TYPE 4, 4X, 12, 13
 IP 67



Specifications:

Input: AC SINGLE OR 3-PHASE: 35 to 600V $3 \sim$, *50/*60/400 Hz *UL approval
 DC OR STORED ENERGY: 35 to 1000V $---$, (Voltages Line-to-Line or Line-to-Ground)

Maximum Rating: 750V $3 \sim$ or 1000V $---$ @ 1.2 Watts, Operating Ambient Air of 55°C Max.

Detection Thresholds: 32V $3 \sim$, 36V $1 \sim$, 32V $---$ (typical cut-off)

$3 \sim$ Led Appearance: 32-159V(FLASH) 160-329V(SHIMMER) 330V+(SOLID)

Temperatures: Operate: -20C to +55C, Code T5
 Storage: -45C to +85C

Terminations: (4) 8 ft, 18 AWG, 90°C @ 1000V, UL-1452
 PVC insulation w/ nylon jacket
 L1- L3: Black w/ bar identification (Fig. 1)
 GND: Green w/ Yellow stripe

Housing: Black Noryl, totally encapsulated including LEDs
 for environment protection

O-Ring Seal: Blue VFMQ Fluorosilicone, UL approved material

Indicators: (8) Red Super Bright LED's

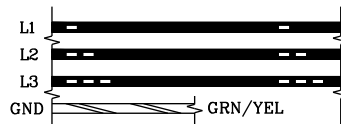

Fig. 1



SYMBOL IDENTIFICATIONS

$3 \sim$ 3 Phase AC rms $---$ DC Volts

 Electric Shock Danger of Death

 Caution  Double Insulated Symbol

INSTALLATION AND OPERATING INSTRUCTIONS:

1. Design, wiring, and service of equipment should only be preformed by qualified personnel familiar with local, state, and related national codes including National Electrical Code (NEC) articles 500, 505 & 506.
2. To meet UL TYPE 4, 4X, 12 or 13 sealing requirements, mount on a flat surface of an enclosure qualifying for a respective TYPE or NEMA rating or equivalent elevated ambient rating.
3. Locate the unit in visual proximity to the control panel ON/OFF disconnect and within wiring distance to incoming Main Lines and Earth Ground. Verify there is no interference with the free operation of the ON/OFF disconnect mechanism.
4. (a) For Standard Mount, refer to knock-out pattern below and Control Drawing No. 212 for assembly.
 (b) For Low Profile Mount with R-3W-SR-BZL kit, refer to knock-out pattern below and Control Drawing No. 213 for assembly.

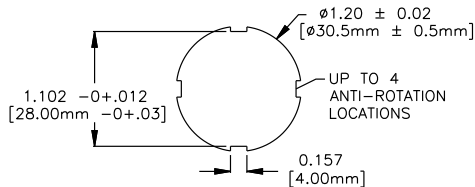

Standard Knockout

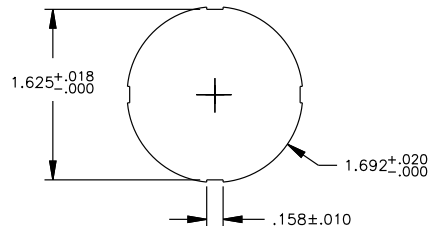

Low Profile Knockout

5. For Delta configured power, connect the 1 bar, 2 bar & 3 bar black wires to L1, L2, & L3 respectively (Fig. 1) on the fused or disconnect side of the 3-Phase line voltage. The Green/Yellow stripe (Grn/Yel) wire **MUST** be connected to Earth Ground. (Fig. 3)
6. Wye configured power with grounded Neutral is connected the same as for Delta in step 5. The Grn/Yel wire **DOES NOT** connect to the neutral but to non-current carrying Earth Ground.
Caution: The neutral will not be monitored for voltage by the Detector, only Phase-to-Phase and Phase-to-Ground voltage will be detected. To include neutral monitoring go to step 7.
7. Ungrounded or high resistance Wye configured power requires (2) additional units to include all possible voltages the Neutral line introduces. Wire as shown in Figure 2.
8. **Verifying Proper Operation:** First disconnect all equipment that may introduce a hazard and notify personnel before powering the panel!
 (a) **TURN POWER ON.** With normal voltage applied, the L1, L2, and L3 indicator pairs will illuminate at rates according to the applied voltage (See table below).

INDICATOR FLASH RATES (L1, L2, L3, GND)

3 ~ LINE-TO-LINE (VAC)	< 32	40	120	240	480	600	750
FLASHES / SEC (TYPICAL)	0	10	29	58	58	58	58
--- OR STORED ENERGY (VDC)	< 32	40	48	110	300	600	1000
FLASHES/SEC (TYPICAL)	0	14	16	29	45	55	64

(Step 8 continued)

(b) GND Indicator Pair Operation: For isolated Delta or 3-Phase WYE applications, it is normal for the “GND” indicator pairs not to illuminate unless a phase is lost producing an unbalanced condition. This peculiarity results when the Phase-to-Phase voltages are balanced resulting in no current to a Neutral connection. The R-3W-SR indicators are current driven; therefore, no net current in the R-3W-SR ground line (connected to Neutral) will cause the “GND” indicators to not illuminate. A leakage resistance path from any phase-to-ground from 2-7 Meg ohms producing a corresponding current from 7-67 μ A in the “GND” wire is adequate for the “GND” indicators to illuminate.

To complete proper installation, verify grounding of the GND lead-wire. Under normal operation, the power system determines if GND LEDs illuminate.

Proceed to GND verification steps below.

- 1.) Apply power to the R-XXX, if the GND LEDs do not illuminate, proceed to step 2.)
- 2.) Remove power and re-establish an electrical safe work condition to allow one phase lead-wire to be disconnected from its source by either disconnecting wire or pull a fuse.
- 3.) Re-apply power and verify that the GND LEDs now illuminate to insure a proper ground connection.
- 4.) Complete installation by removing power and reconnecting the phase lead-wire or fuse and reapply power and re-verify that L1, L2, & L3 LEDs illuminate.



BEFORE OPENING A PANEL, TURN POWER OFF! (Steps 1-8 must first verify proper operation of indicators.) SAFETY PROCEDURES STILL APPLY: Before working on an electrical conductor, verify zero electrical energy with proper voltage testing instrument and the proper procedure as per NFPA 70E Article 120.5.



COUPER L'ALIMENTATION AVANT D'OUVRIER UN PANNEAU a (Les étapes 1 à 8 servent tout d'abord à vérifier le bon fonctionnement des indicateurs.) LES CONSIGNES DE SÉCURITÉ SONT TOUJOURS APPLICABLES : avant de travailler sur un conducteur électrique, vérifier que l'énergie électrique est nulle à l'aide d'un instrument de détection de tension convenable et la procédure appropriée selon NFPA 70E Article 120.5.

MAINTENANCE

1. For O-ring inspection, follow the respective Control Drawing directions pages 7 & 8.
2. For cleaning the front blue label or the information sticker, use only clean water and a soft cloth.

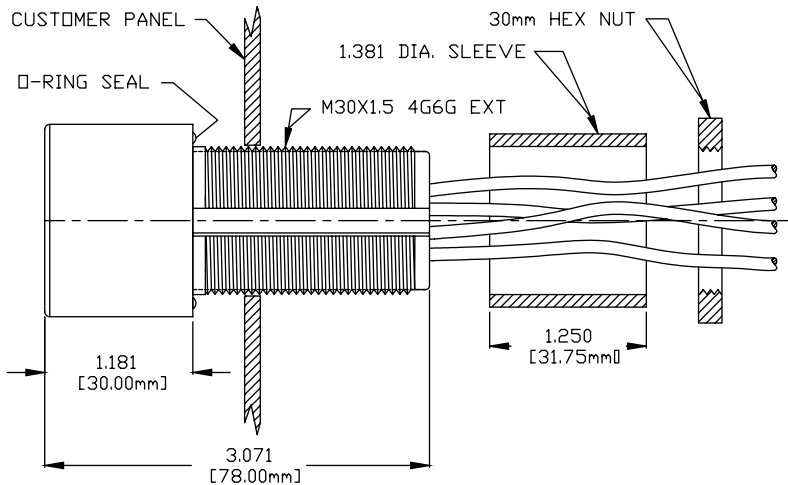
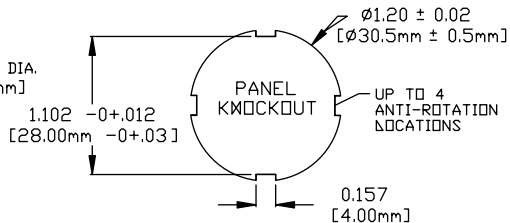
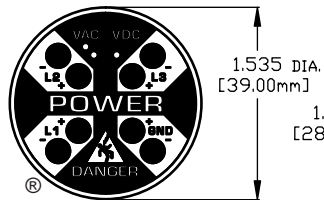

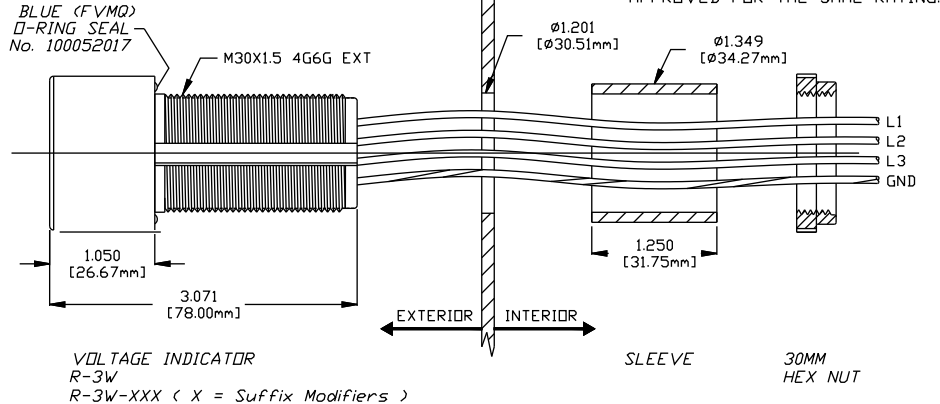

CONTROL DRAWING No. 212



Installation Notes:

1. The mounting surface must be clean and smooth. Tighten the Hex nut until the external head seats against the mounting surface so the O-ring is fully compressed. Do not overtighten.

Uninstalling for Inspection:

-  WARNING: EXPOSURE TO SOME CHEMICALS MAY DEGRADE THE SEALING PROPERTIES OF THE FLUOROSILICONE FVMQ O-RING SEAL. FOR REPLACEMENT, USE PT. NO. 100052017.
 -  WARNING: SUBSTITUTION OF O-RING No. 100052017 OR ASSEMBLY PARTS MAY VOID SUITABILITY FOR LOCATION.
1. Periodic inspection of the O-ring seal is recommended. Replace O-ring if any degradation is found.

CONTROL DRAWING No. 213 GENERAL APPLICATIONS

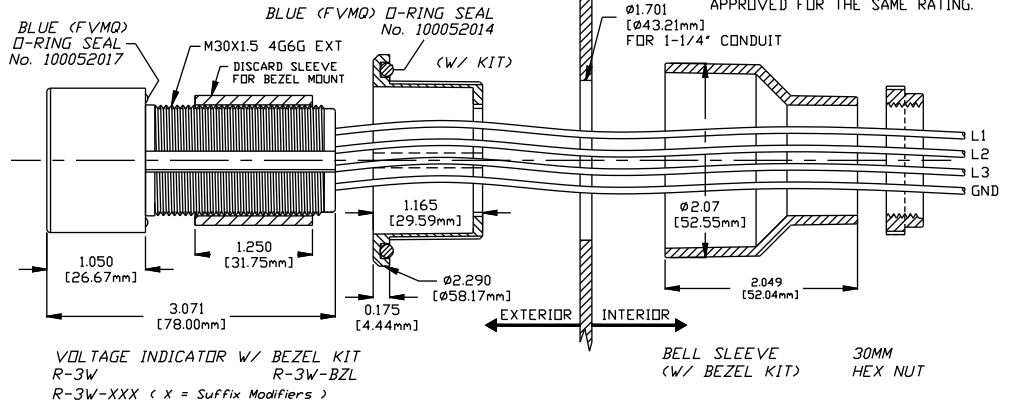

Installation Notes:

1. The mounting surface must be clean and smooth. Tighten the Hex nut until the outside ledge of the Bezel seats against the mounting surface so the O-ring is fully compressed. Do not overtighten.

Uninstalling for Inspection:

- WARNING:** EXPOSURE TO SOME CHEMICALS MAY DEGRADE THE SEALING PROPERTIES OF FLUOROSILICONE (FVMQ) O-RING SEALS, REFER TO A CHEMICAL COMPATABILITY CHART.
 - WARNING:** SUBSTITUTION OF O-RINGS OR ASSEMBLY PARTS MAY VOID SUITABILITY FOR LOCATIONS.
1. Periodic inspection of the (2) O-ring seals is recommended. Replace the O-ring(s) if any degradation is found.
 2. For replacement of the R-3W O-ring, use part number 100052017.
For replacement of the Bezel O-ring, use part number 100052014.

CONTROL DRAWING No. 212

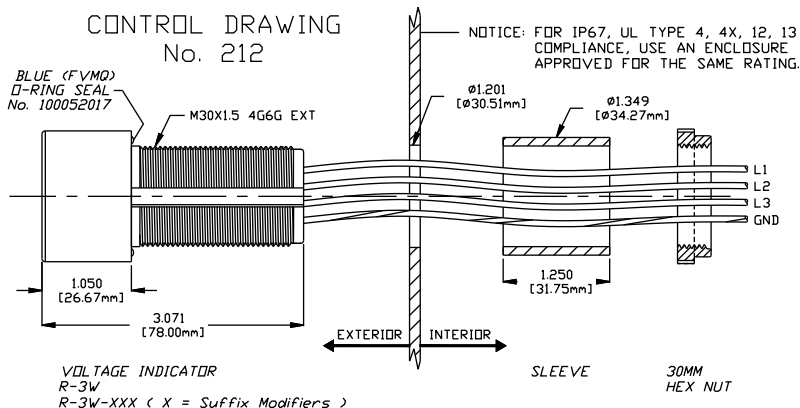

Remarques sur l'installation:

1. La surface de montage doit être propre et lisse. Serrer l'écrou hexagonal jusqu'à ce que la base externe repose sur la surface de montage, de façon à ce que le joint torique soit complètement comprimé.
Ne pas trop serrer.

Démontage pour l'inspection:

- ⚠ AVERTISSEMENT: L'EXPOSITION À CERTAINS PRODUITS CHIMIQUES PEUT DÉGRADER LES PROPRIÉTÉS D'ÉTANCHÉITÉ DU JOINT TORIQUE EN FLUOROSILICONE (FVMQ). POUR REMPLACER LE JOINT, UTILISER LE NO. DE PIÈCE 100052017.**
- ⚠ AVERTISSEMENT: LA SUBSTITUTION DU JOINT TORIQUE No 100052017 OU DE PIÈCES DE L'ASSEMBLAGE PEUT ANNULER LA CONVENANCE À L'EMPLACEMENT.**
1. L'inspection périodique du joint torique est recommandée. Remplacer le ou les joint(s) torique(s) si des signes de dégradation sont détectés.

CONTROL DRAWING No. 213 GENERAL APPLICATIONS

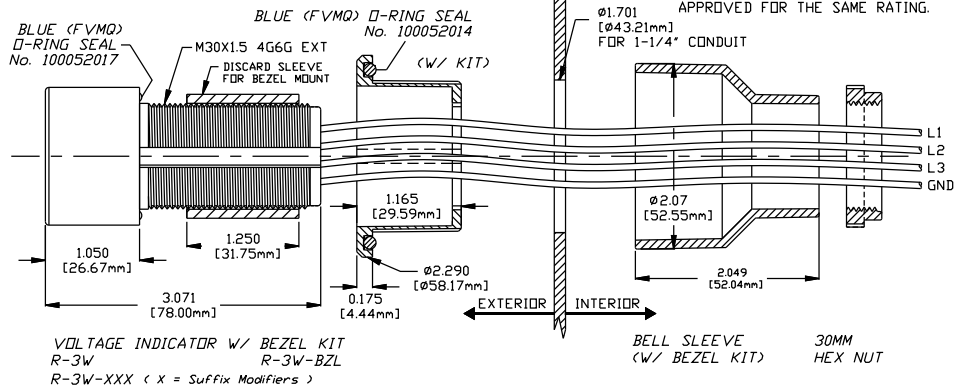

Remarques sur l'installation:

1. La surface de maontage doit être proper et lisse. Serrer l'écrou hexagonal jusqu'à ce que le bord extérieur de la collarette repose sur la surface de montage, de façon à ce que le joint torique soit complètement comprimé.
Ne pas trop serrer.

Démontage pour l'inspection:



AVERTISSEMENT: L'EXPOSITION À CERTAINS PRODUITS CHIMIQUES PEUT DÉGRADER LES PROPRIÉTÉS D'ÉTANCHÉITÉ DES JOINTS TORIQUES EN FLUOROSILICONE (FVMQ). SE RÉFÉRER AU TABLEAU DE COMPATIBILITÉ CHIMIQUE.



AVERTISSEMENT: LA SUBSTITUTION DU JOINT TORIQUE No 2 OU DE PIÈCES DE L'ASSEMBLAGE PEUT ANNULER LA CONVENANCE AUX EMBLEMES.

1. Il est recommandé d'inspecter les deux joints toriques périodiquement. Remplacer le ou les joint(s) torique(s) si des signes de degradation sont détectés.
2. Pour le remplacement du joint torique UPA, utiliser le numéro de piece 100052017.
Pour le remplacement du joint torique de la collarette, utiliser le numéro de piece 100052014.

Standard Mount



R-3W-SR

Bezel Mount



R-3W-SR & R-3W-BZL

**Many other variations available upon request.
Please call 1-800-280-9517 or visit
www.pesd.com**

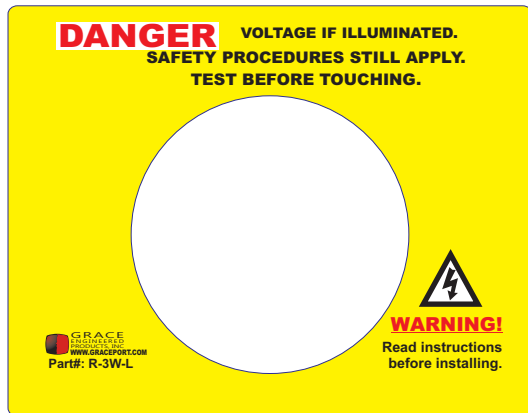

Part#: R-3W-L*



Part#: R-3W-NP-F*

*These labels install around the R-3W-SR with no affect on its UL certification. The lables are not UL approved.

THREE PHASE WYE, 4W + GND

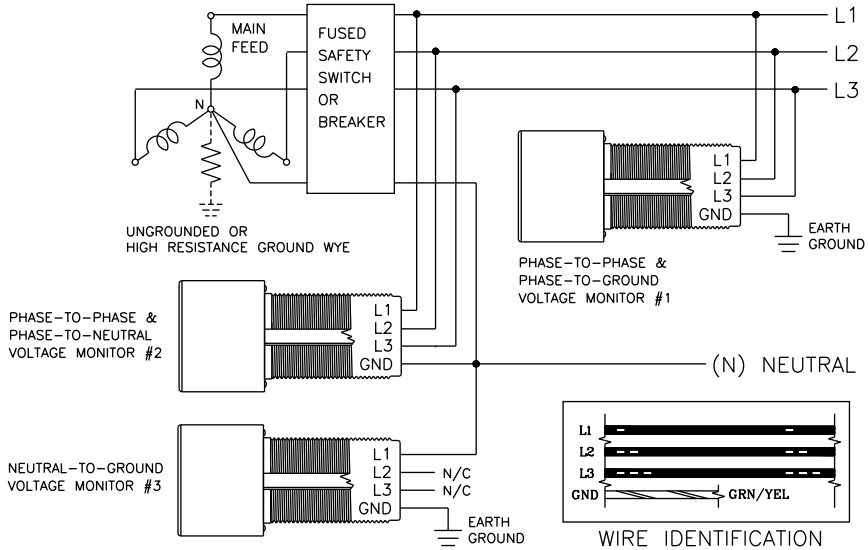

Fig. 2

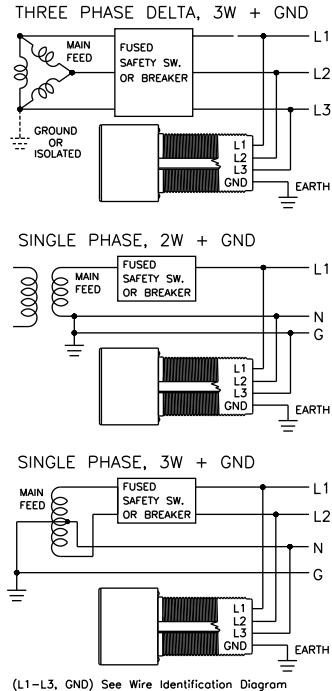

Fig. 3

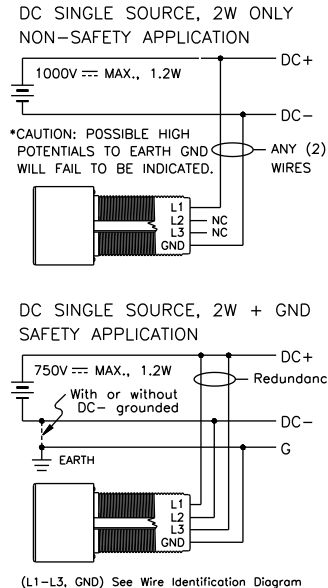



Fig. 4

California Proposition 65

 **WARNING:** Cancer and Reproductive Harm
www.p65Warnings.ca.gov

California Proposition 65

 **AVERTISSEMENT:** Cancer et Troubles de l'appareil reproducteur
www.p65Warnings.ca.gov