

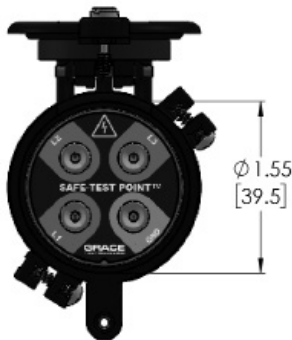

**GRACE**  
PESDs®

# R-3M-1K Dust Cap Assembly Instructions

- Ensure the procedure label is applied onto the cabinet before installation.
- Install the Safe-Test Point™ per instructions.
- Fully seat the dust cap assembly over the Safe-Test Point™.
- Rotate the dust cap assembly to adjust the orientation as needed (horizontal/vertical).
- Tighten the 2x #1 Phillips head screws provided on the side and gently adjust the screws till gap measures  $0.060'' - 0.070''$  (1.5mm -1.8mm). Do not over tighten.
- Close the cap and tighten the front captive screw to the maximum torque of 3IN LBF (0.3NM).

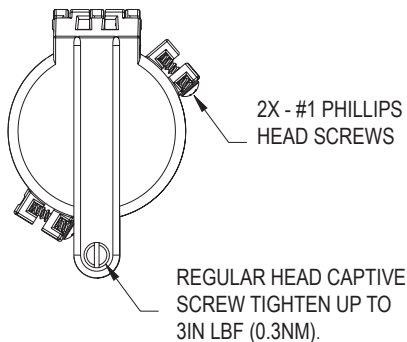

**See Figure 1 on reverse for additional views**

**Warning:** Verify an electrical conductor has been de-energized using an adequately rated test instrument before working on it. Follow appropriate Energy Control (Lockout/Tagout) procedures as per OSHA Subpart S.



**GRACE**  
TECHNOLOGIES

Davenport, IA • 800-280-9517 • [www.pesd.com](http://www.pesd.com)

SS-R3MT1KCAP-IG-EN 2204

Figure 1

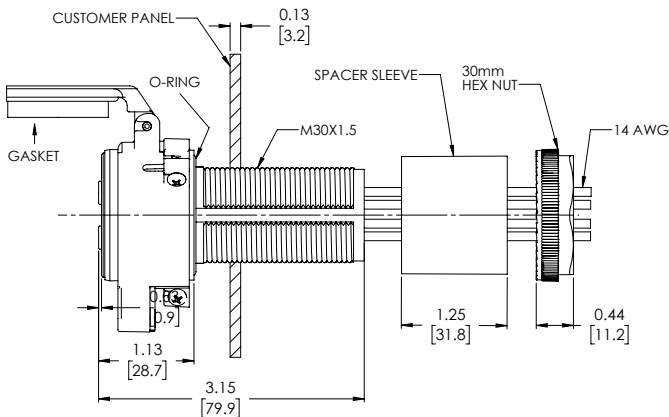

## Sample Procedure:

- 1) Verify the test instrument is calibrated and properly rated for application.
- 2) Verify the test instrument to a known voltage source.
- 3) Verify there is voltage illumination on the voltage indicator.\*
- 4) Open the dust cap and insert the test instrument probes into the test point and measure the voltage between phase to phase and phase to ground to verify voltage presence.
- 5) Open Isolator.
- 6) Verify there is no LED illumination on the voltage indicator.\*
- 7) Re-insert the Test Instrument probes into the test point and measure the voltage between phase to phase and phase to ground to verify voltage absence.
- 8) Re-verify test Instrument to a known voltage source.
- 9) Upon completion of work, close the dust cap on the test point, close isolator, and verify proper operation of voltage indicator.

\*If used with a voltage indicator.

**Note:** The voltage accuracy of the test point is - 3.3% and test instrument will read small mV due to the high impedance circuit in the test points.