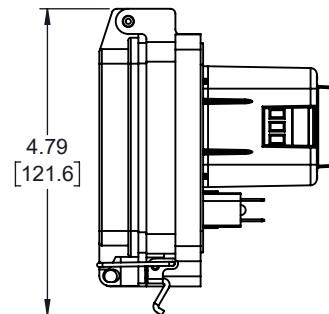
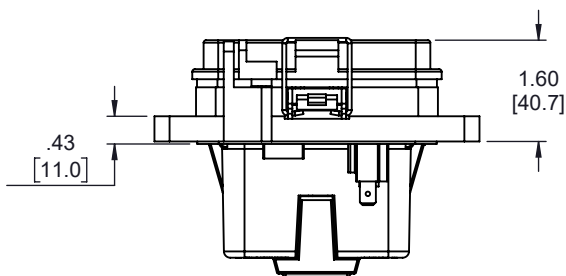
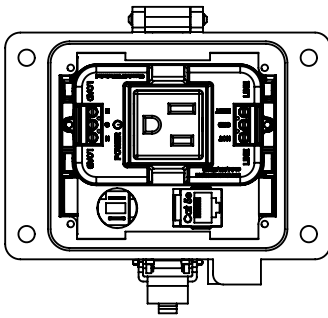
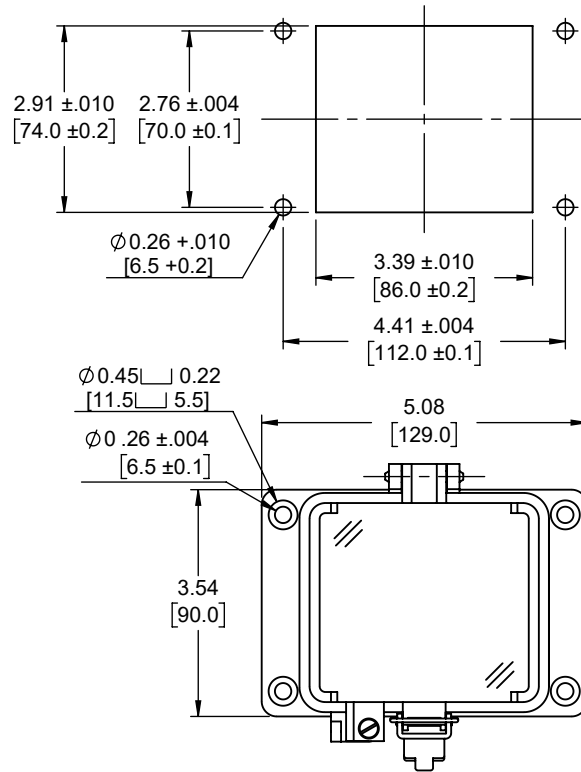
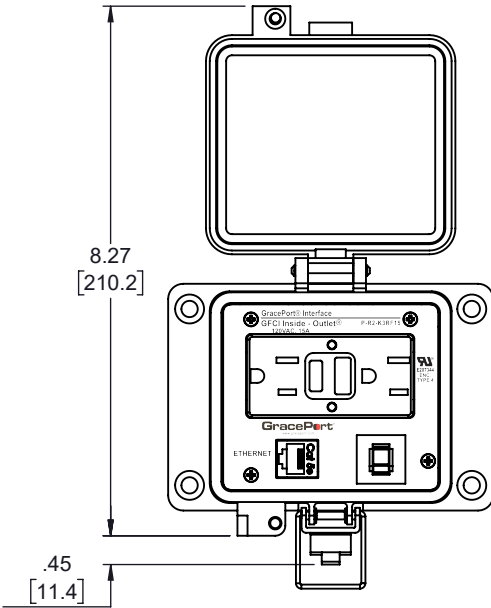

Panel Cutout

NOTE:

- 1) REFER TO INSTALLATION INSTRUCTIONS TO ENSURE PROPER INSTALLATION.
- 2) ALWAYS FOLLOW YOUR LOCAL/FACILITY ELECTRICAL CODES AND PROCEDURES.
- 3) FOR DETAILED COMPONENT WIRING AND SPECIFICATIONS, REFER TO THE APPLICABLE DATA SHEETS.
- 4) COMPONENT LOCATIONS OUTLINED IN DRAWING ARE APPROXIMATE
- 5) FOR ACTUAL PRODUCT CONFORMITY, LISTINGS AND CERTIFICATIONS, REFER TO FINISHED PRODUCT FACEPLATE DRAWING, OR CONSULT FACTORY.